

PAN-Z

designed by Marcia Morrison

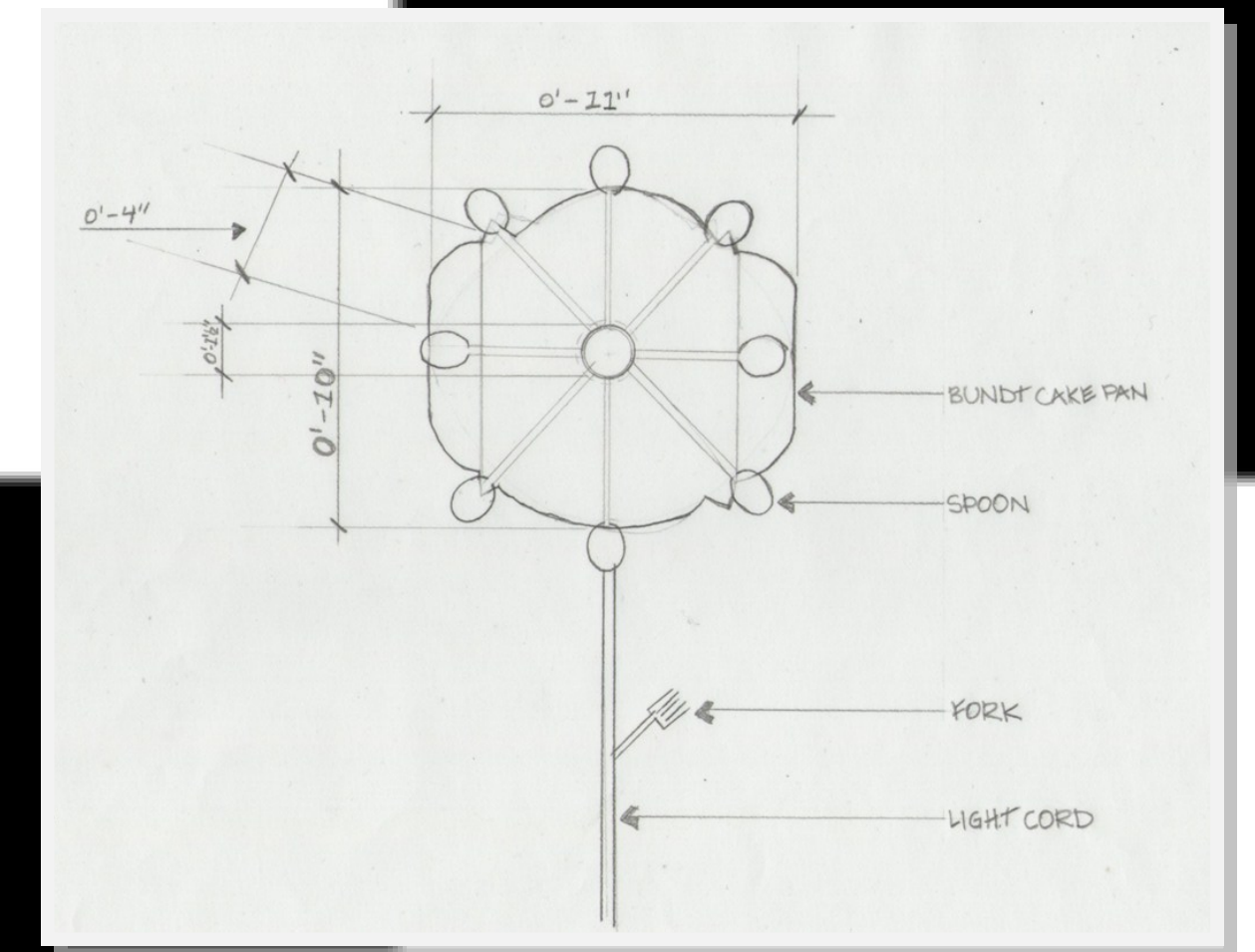

FRONT VIEW

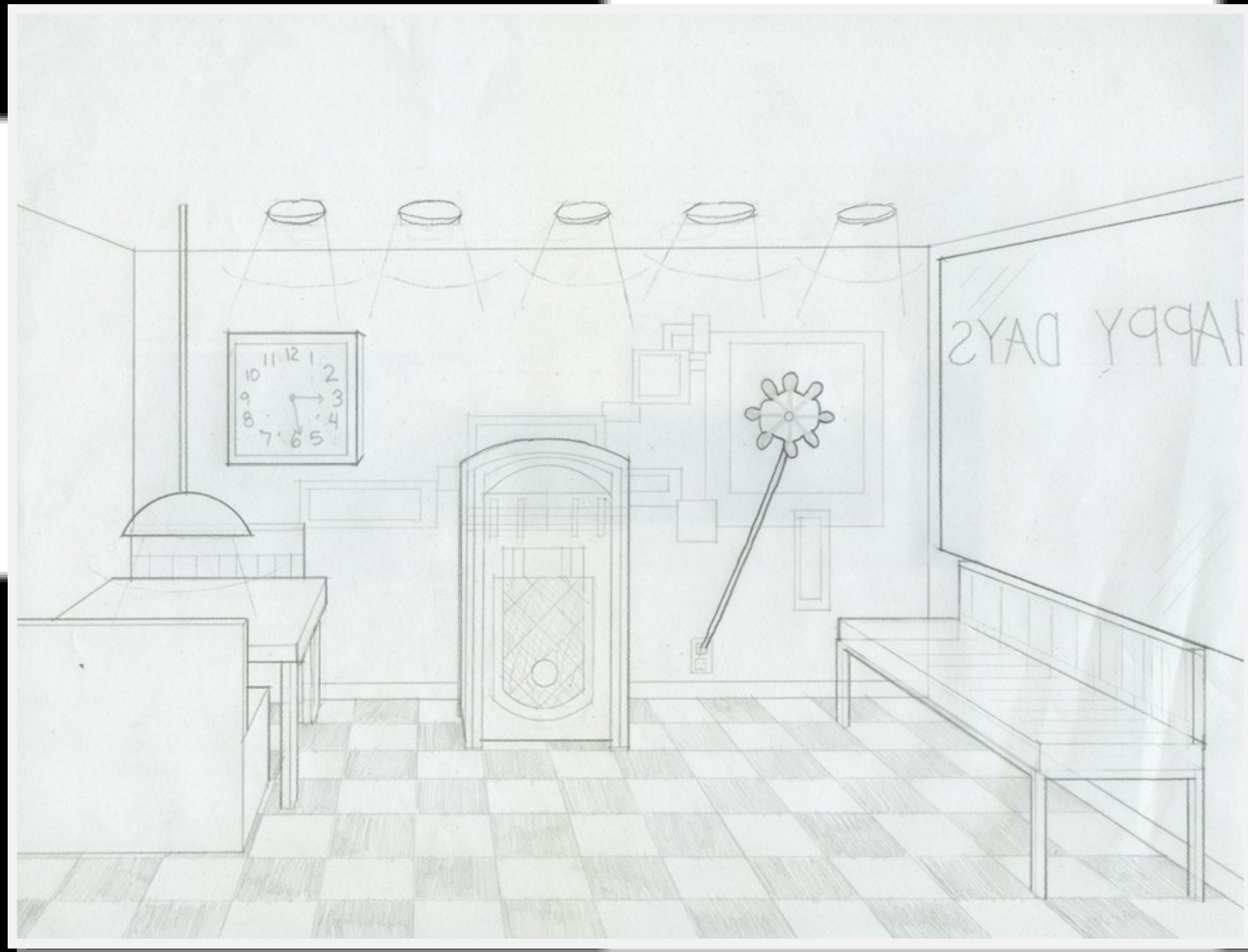
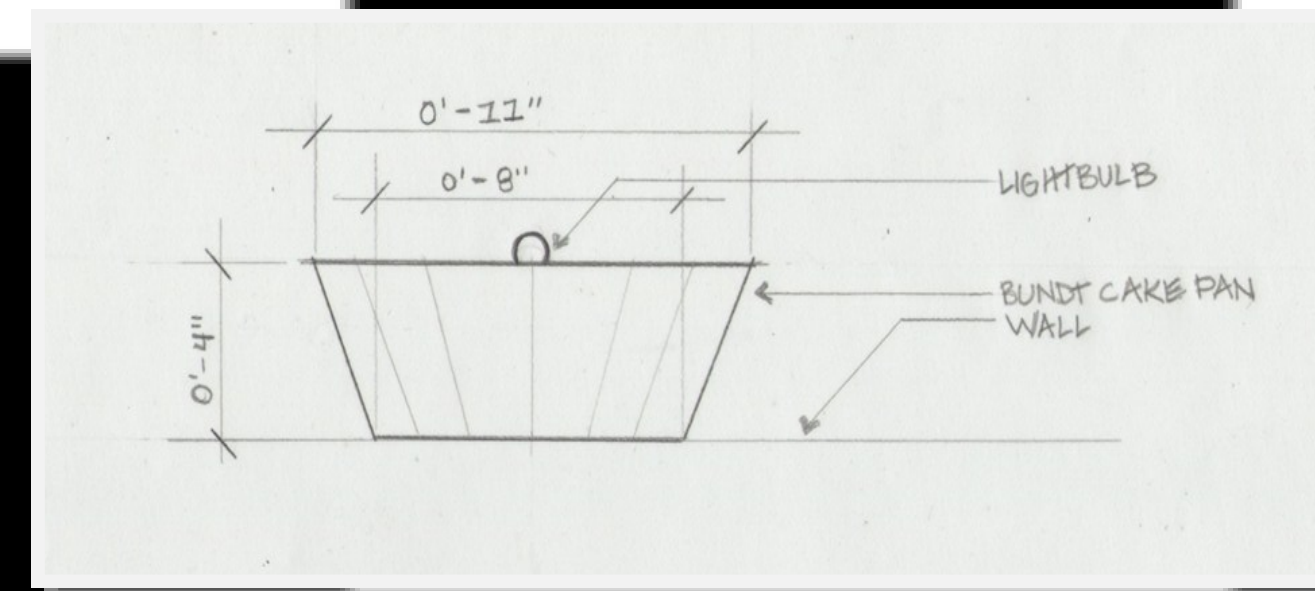

TOP VIEW

Sustainable Design has become a major part of Interior Design. Designer's goals are to use resources that are not depleted or permanently damaged. This means using different products, such as pre-consumer waste, post-industrial waste, biodegradable materials, and repurposed products. For the sustainable light, I focused on repurposed products. For this project, I thought about products that people use every day. I then thought about something that I can use that would be accessible in a residence hall. Kitchen utensils came to mind. We all have to eat to survive, so using kitchen products is something people do daily. I decided to use a Bundt cake pan because it mimics a lamp shade that is found on many lights today. I then had to decide what to do with the cord of the light. To utilize the cord, I decided to have the light be mounted onto the wall. The light is transformed into a flower and the cord becomes the stem of the flower. To make the light look more like a flower, I decided to use spoons to look like petals. To have the appearance of movement through the light, I used knives to mimic the lines on the pan and then have them melt into the spoons. The spoons are literally melted into the knives because they are welded together. To continue the kitchen utensil theme, the leaves on the stem are made from forks. The light, itself, sticks out of the pan and is dulled so that it is not too bright. Most of the materials came from second-hand stores and thrift shops. The only item that was bought was the electrical cord. The spoons, forks and knives are all mix matched to add a more rustic feel. This light shows how items can be reused and repurposed for different uses.

The name of the light is Pan-Z because it is made from a pan and it is named like the pansy flower. The light utilizes many different design elements and principles. The form of the pan is similar to that of a flower. It appears to look like a flower because of the radial symmetry of the utensils. The utensils are not all identical, but their placement is. There is also repetition with all of the spoons to make the radial shape. In a flower, the focus, or hierarchy, is usually the center. This light has the same effect because the bulb is going to be in the center; causing the emphasis to be on the center and brightest object. The knives and spoons follow the lines of the cake pan to help the eye be drawn towards the light. The lines of the knives and spoons add texture because of the pattern from the welding.

Pan-Z would fit in a retro café because of the rustic colors, neutral colors and materials used. The light would work also work well in a café because of the kitchen utensils. The Bundt cake pan would work in a café because they make cakes and other items in them. The light was inspired by an actual café that has an antique store attached to it. The antique look of the light would go well with the atmosphere of the restaurant.

Since the light is made of second hand materials, it has many different uses. If the light was no longer needed, the materials could be dismantled and donated back to a secondhand store. The materials could also be melted down into metal and formed into something new.